

Forsta Filters Inc.

[www.forstafilters.com](http://www.forstafilters.com)

PO Box 341830,

Los Angeles, CA 90034

[info@forstafilters.com](mailto:info@forstafilters.com)

888.9-FORSTA

Ph: 310.837.7177

Fx: 310.837.6477

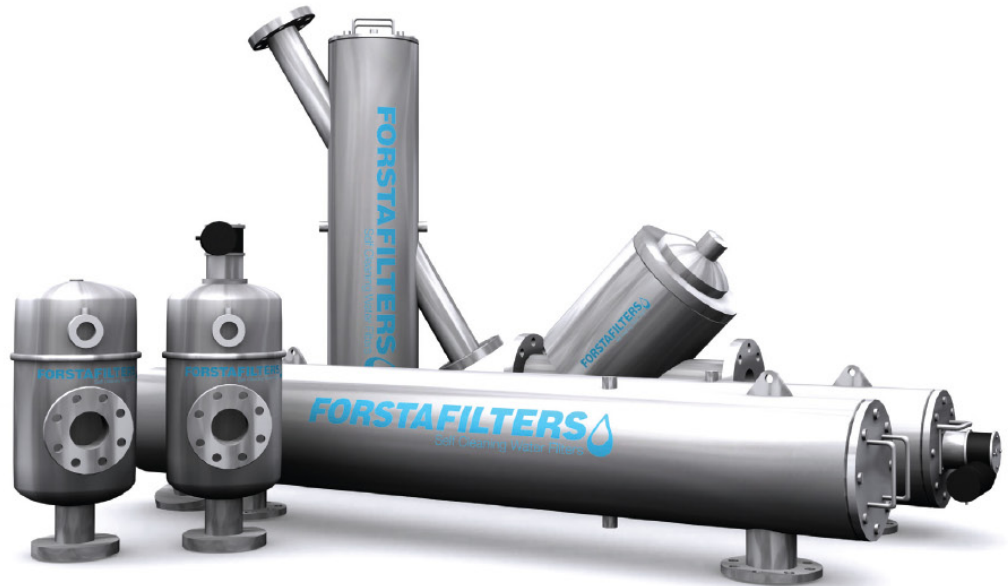

**180 SERIES  
SELF CLEANING WATER FILTER  
OPERATION & MAINTENANCE MANUAL**

# CONTENTS

<b>Filter Basics</b>	<b>1</b>
<b>Installation Requirements</b>	<b>2</b>
Couplings	2
Flush Line	2
Hydraulic Connections	3
Hydraulic Piston	3
<b>Filter Performance</b>	<b>3</b>
Normal Operation	3
Backwash Cycle	4
<b>Flow &amp; Pressure Requirements</b>	<b>5</b>
<b>Maintenance &amp; Spare Parts</b>	<b>5</b>
Startup	5
Shutdown	6
Periodic Maintenance	6
Spare Parts	7
Particle Remover	7
Hydraulic Piston	8
<b>Installation &amp; Wiring</b>	<b>9</b>
180 Series Filter	9
2x180 Series Filters in Parallel	10
<b>Warranty</b>	<b>11</b>

# Filter Basics

The Forsta 180 Series is a self cleaning screen water filter. The major components include the Filter Housing (1), Coarse Screen pre-filter (11), Fine Screen filter element (2), Particle Remover (3), Hydraulic Piston (8), and Backwash Valve (12).

180 SERIES FILTER - GENERAL LAYOUT

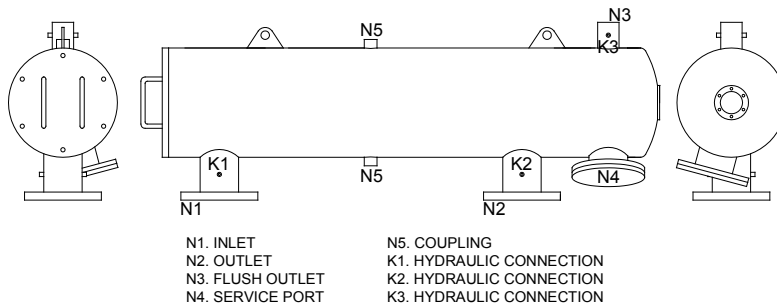

180 SERIES FILTER - ASSEMBLED VIEW

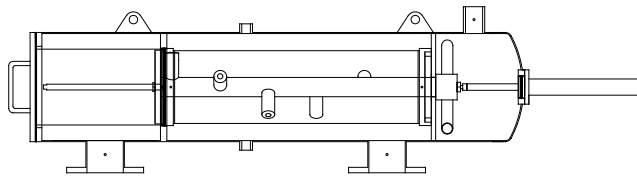

180 SERIES FILTER - EXPLODED VIEW

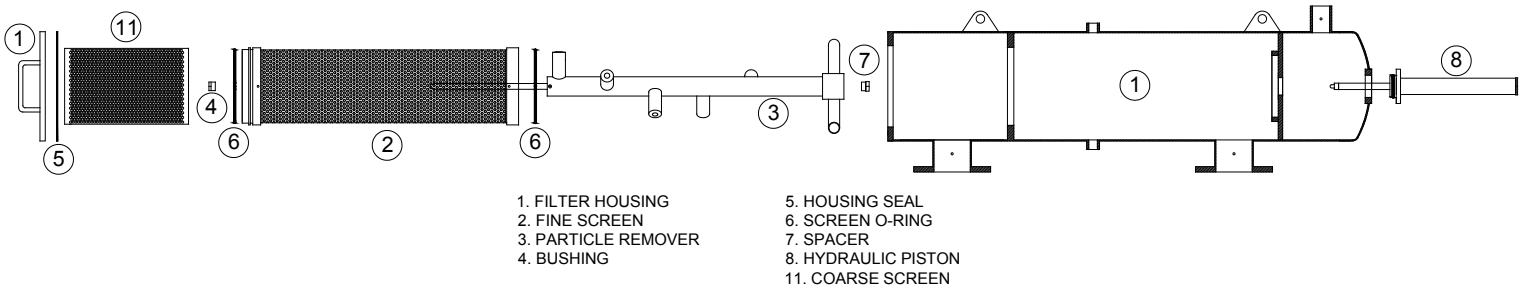

## Installation Requirements

180 Series filters may be mounted directly on the inlet (N1) and outlet (N2) flanges, and positioned in any orientation. Isolation valves should be installed at the inlet and outlet, and a bypass valve should be installed between the flanges. This will allow the filter to be taken offline without disruption to water flow.

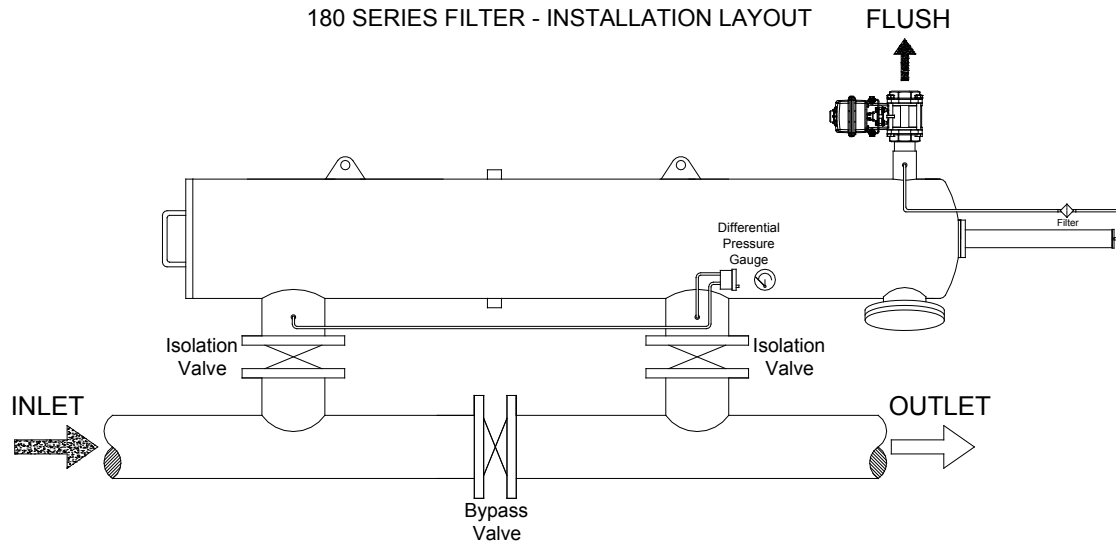

There should be adequate clearance around the filter to allow for easy maintenance access, including a minimum of 24" from the back (piston side). The minimum clearance on the front (cover) depends on the model. There must be enough room to remove the coarse screen and fine screen periodically.

### COUPLINGS

It is recommended to use the 1" threaded half couplings (N5) for air bleed-off during startup, and draining when taking the filter offline. Valves may be installed at both locations, otherwise the couplings remain plugged.

### FLUSH LINE

The piping for the flush valve must have no backpressure. It is strongly recommended to use oversized piping to accommodate this requirement. For example, if the 180 Series filter uses a 2" valve, the recommended pipe is a minimum of 3". For a 1" valve, 1.5" or 2" pipe must be used.

To minimize backpressure on the flush line, it is also important to avoid elevation gain in the flush line. Even small elevation gains will reduce the filter's ability to perform an effective backwash cycle. If flush water must be transported to higher elevation, it is recommended to pipe the flush line to a storage tank first, and then pump it out to higher elevation.

## HYDRAULIC CONNECTIONS

Each flanged connection nozzle (N1 & N2) on the 180 Series filter has two ¼" threaded couplings. One may be used to install a pressure gauge or other sensor equipment. The other ¼" coupling will be used to connect hydraulic tubing from the differential pressure switch to the filter. The high pressure line is fitted to the inlet, and low pressure fitted to the outlet.

## HYDRAULIC PISTON

The piston (8) is mounted on the domed end of the filter. ¼" tubing must be installed from the fitting located on the back of the piston to the hydraulic connection (K3) on the flush outlet (N3). A filter is installed on the hydraulic tubing to protect the piston.

## **Filter Performance**

### NORMAL OPERATION

During normal operation of the filter, dirty water enters through the inlet and passes through the coarse screen. Any abnormally large debris is caught here and prevented from possibly damaging the fine screen or particle remover.

Water then travels down the center of the filter and is strained across the fine screen. As water passes from inside the screen to outside, suspended particles are trapped on the fine screen and continue to buildup, eventually creating a drop in pressure at the outlet of the filter.

### 180 SERIES FILTER - NORMAL OPERATION

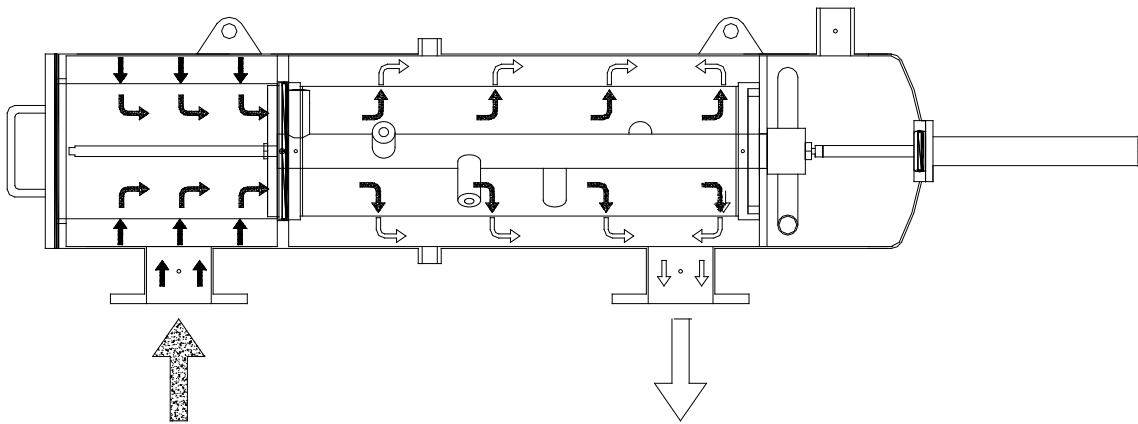

This drop in outlet pressure is monitored by the differential pressure gauge, which at seven PSID (pounds per square inch differential) sends a signal to the controller to initiate a backwash cycle.

This drop in outlet pressure is monitored by the differential pressure gauge, which at seven PSID (pounds per square inch differential) sends a signal to the controller to initiate a backwash cycle.

## BACKWASH CYCLE

The controller opens the flush valve, which causes a drop in pressure in the hydraulic motor chamber. This creates a low pressure path inside the particle remover, which acts as a vacuum at the end of the suction nozzles, removing the built up debris from the inside of the fine screen.

### 180 SERIES FILTER - BACKWASH CYCLE

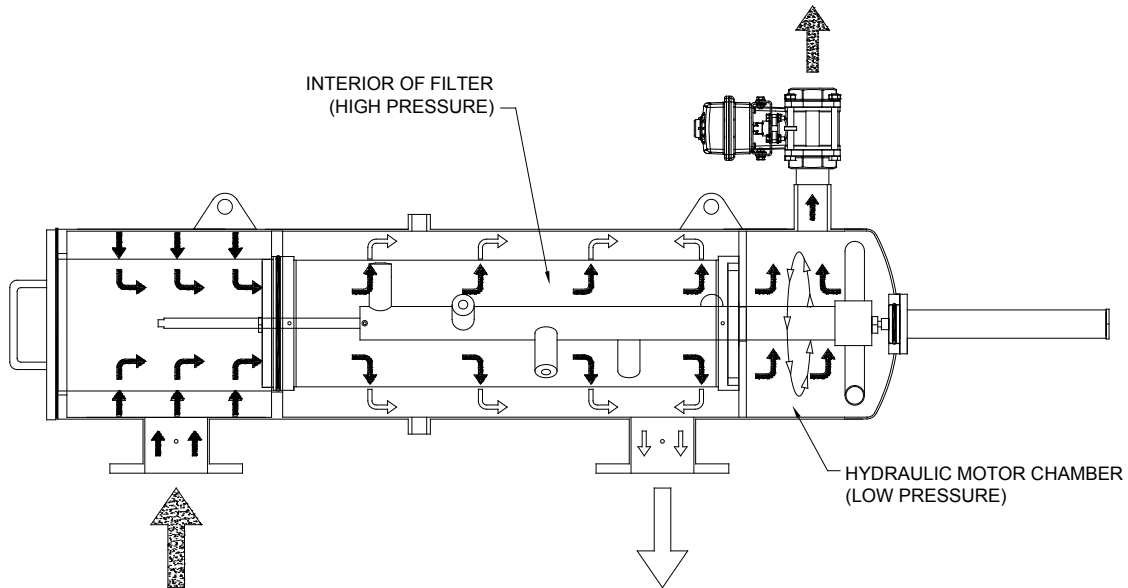

Water flows through the suction nozzles, down the interior of the particle remover, and out the hydraulic motor. The rapid flow of water through the hydraulic motor forces the entire particle remover to rotate, enabling each suction nozzle to cover a radial strip of screen. And the pressure difference between the interior of the filter and the hydraulic motor chamber drives the particle remover toward the hydraulic piston.

The piston depressurizes during the backwash cycle, and expels the volume of water from its chamber. This acts as a timer, gradually allowing the particle remover to drive the piston rod into the piston, assuring that the suction nozzles cover the entire surface of the fine screen. When the piston reaches the end of its stroke, the backwash cycle is complete, and the flush valve closes. Pressure inside the hydraulic motor chamber normalizes with the rest of the filter, and the piston pushes the particle remover back to its original position.

After the piston and particle remover move back to their original positions, the filter returns to normal operation. During the entire backwash cycle, the main flow through the filter is never disrupted. the normal system flow AND the additional flow required during backwash. The additional flow depends on the filter model and what valve is used.

## Flow & Pressure Requirements

Forsta 180 Series filters have a minimum pressure requirement of 40 PSI. This includes any pressure loss incurred during the backwash cycle. Therefore the pump performance is a crucial component in determining whether the filter will perform correctly.

Pump manufacturers will provide the performance data in the form of a pump curve. This is a graph that plots pressure vs. flow rate. A pump is considered adequate for an application if it can maintain a minimum of 40 PSI while pumping the normal system flow AND the additional flow required during backwash. The additional flow depends on the filter model and what valve is used.

### 180 SERIES FILTER - VALVE FLOW RATES

<u>Valve</u>	<u>Flow Rate</u>
1"	40 gpm
1.5"	100 gpm
2"	220 gpm

## Maintenance & Spare Parts

### STARTUP

When pumping water through the Forsta 180 Series for the first time or after it has been empty, it is important to follow a correct sequence of valve actuation in order to prevent damage to the filter components.

With both isolation valves closed and the bypass valve open, the correct sequence is:

1. Slowly open the inlet isolation valve letting water flow into the filter. If installed, bleed out the air through a valve on the top of the filter body. Let the entire filter fill with water before moving to the next step.
2. Close the bypass valve.
3. Open the outlet isolation valve.

If it is not an option to close the bypass valve momentarily before opening the outlet valve, then both may be actuated simultaneously.

## SHUTDOWN

To remove the filter from operation, reverse the steps used for startup.

1. Close the outlet valve.
2. Open the bypass valve
3. Close the inlet valve, and slowly open the drain valve on the bottom of the filter housing. There will be residual pressure in the tank still, so use caution when draining.

If it is not an option to close the outlet valve momentarily before opening the bypass, then both may be actuated simultaneously.

## PERIODIC MAINTENANCE

Once a year, or whenever pumps or water flow is shutdown, it is recommended to open and inspect the filter components. Access to the internal components is through the front cover and service port (N4).

Remove the piston from the back plate and drain the water from the piston chamber. Verify that the piston rod is moving smoothly in and out, and inspect the piston tip for wear.

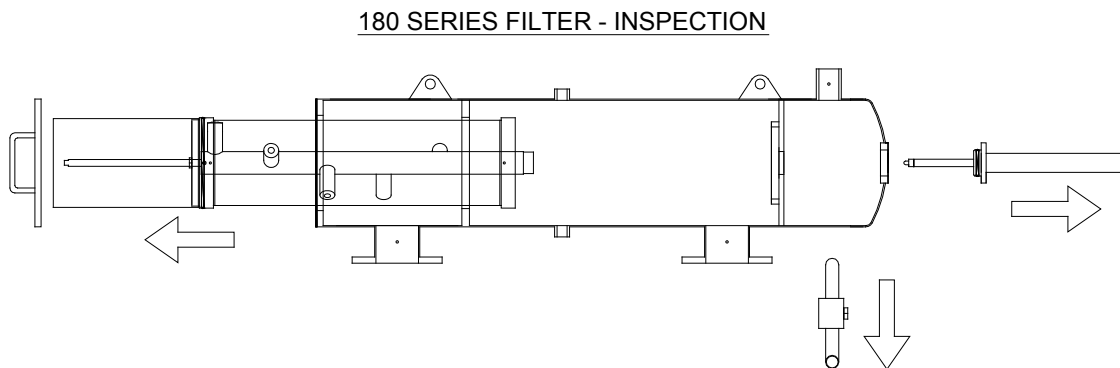

Remove the hydraulic motor from the rest of the particle remover by accessing it through the service port. It has a left hand thread, so it must be turned to the right to loosen it.

Remove the screen and particle remover, using the front cover for access. Both should be extracted in one piece. Separate the two items and inspect both for damage. The screen mesh and bushing should be inspected for wear.

Also inspect the particle remover rod and suction nozzles for wear.



## SPARE PARTS

Spare parts for maintenance for two years include:

- Screen O-rings (p/n 6)
- Cover Seal (p/n 5)
- Suction Nozzles (p/n 3.5)
- Bushing (p/n 4)
- Differential Pressure Gauge (p/n 18)
- Piston Shaft Tip (p/n 8.9)
- Piston Seal Kit (p/n 8K)
- Mini-Filter (p/n 16)
- Valve (p/n 12)
- Fine Screen (p/n 2)
- Particle Remover (p/n 3)
- Spacer (p/n 7)

### 180 SERIES PARTICLE REMOVER - PART LIST

ITEM	PART NUMBER
Particle Remover	3
Rod	3.1
Rod Counternut	3.2
Casing	3.3
Rotating Sprinkler	3.4
Suction Nozzle	3.5

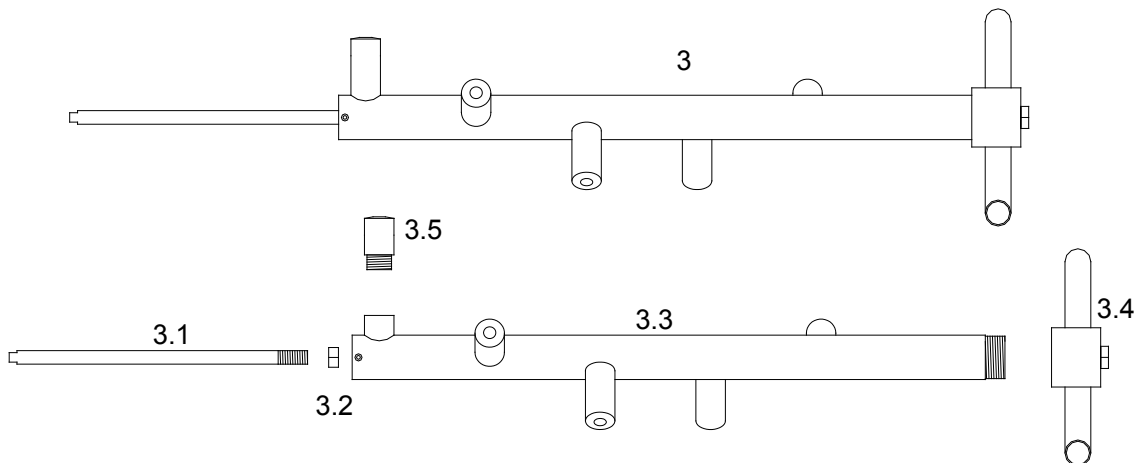

180 SERIES PISTON - PART LIST

ITEM	PART NUMBER
Hydraulic Piston	8
Snap Ring	8.1
Head Ring	8.2
Shaft U-Cup	8.3
Head O-Ring	8.4
Sleeve O-Ring	8.5
Shaft O-Ring	8.6
Pin Holder	8.7
Position Pin	8.8
Shaft Tip	8.9
Shaft	8.10
U-Cup Holder	8.11
Casing U-Cup	8.12
U-Cup Holder Cap	8.13
Casing	8.14
Casing Cap	8.15
Piston Head	8.16

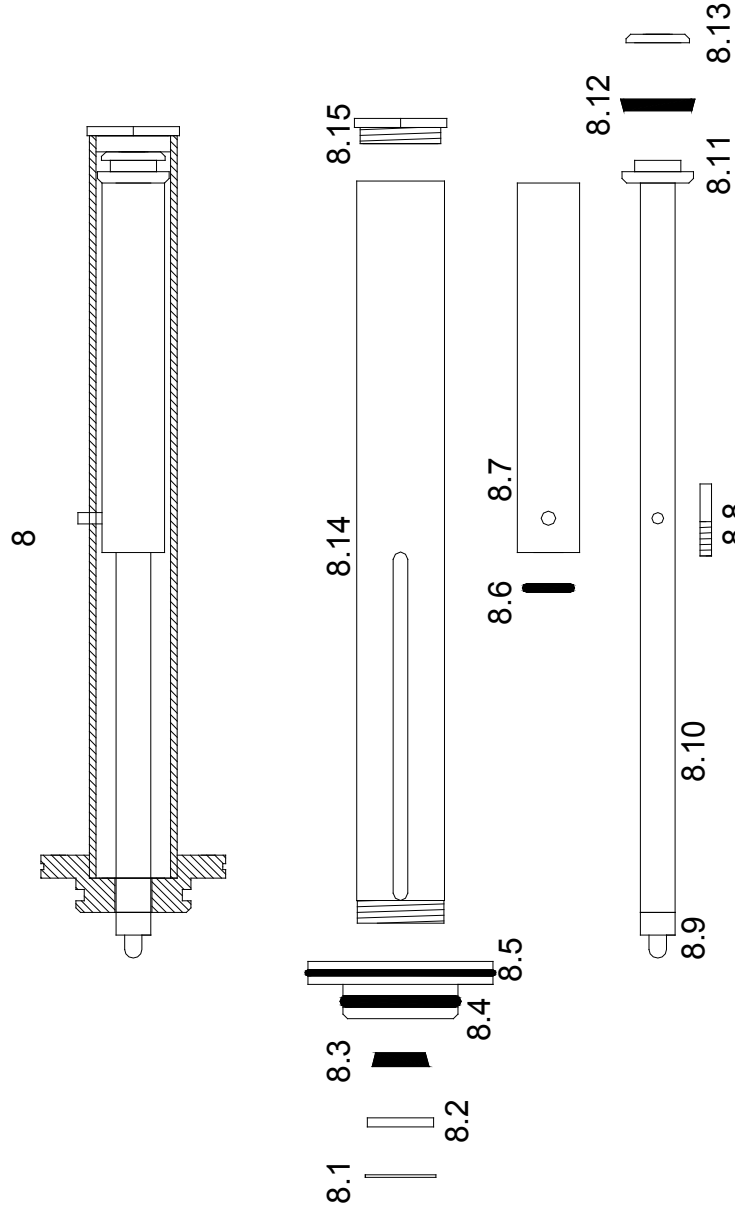

100 SERIES FILTERS - EU-Z WIKING

EC-2-110/220

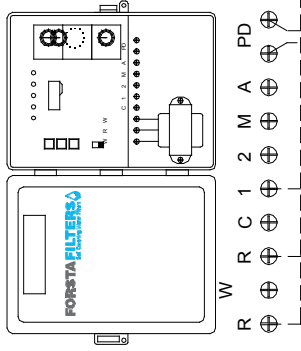

VALVE CONNECTIONS  
 R(left), --- RED  
 R(right), --- BLACK  
 1, --- WHITE

FLUSH

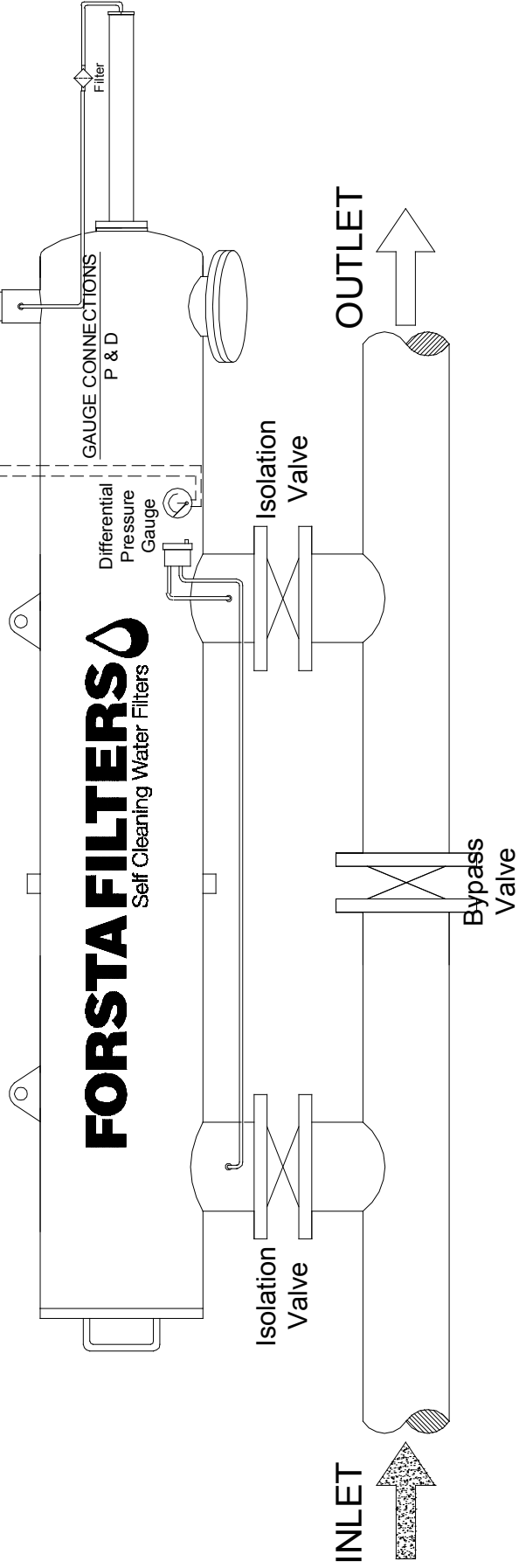

**FORSTA FILTERS**  
 Self Cleaning Water Filters

2x180 SERIES FILTER - EC-2 WIRING

FLUSH

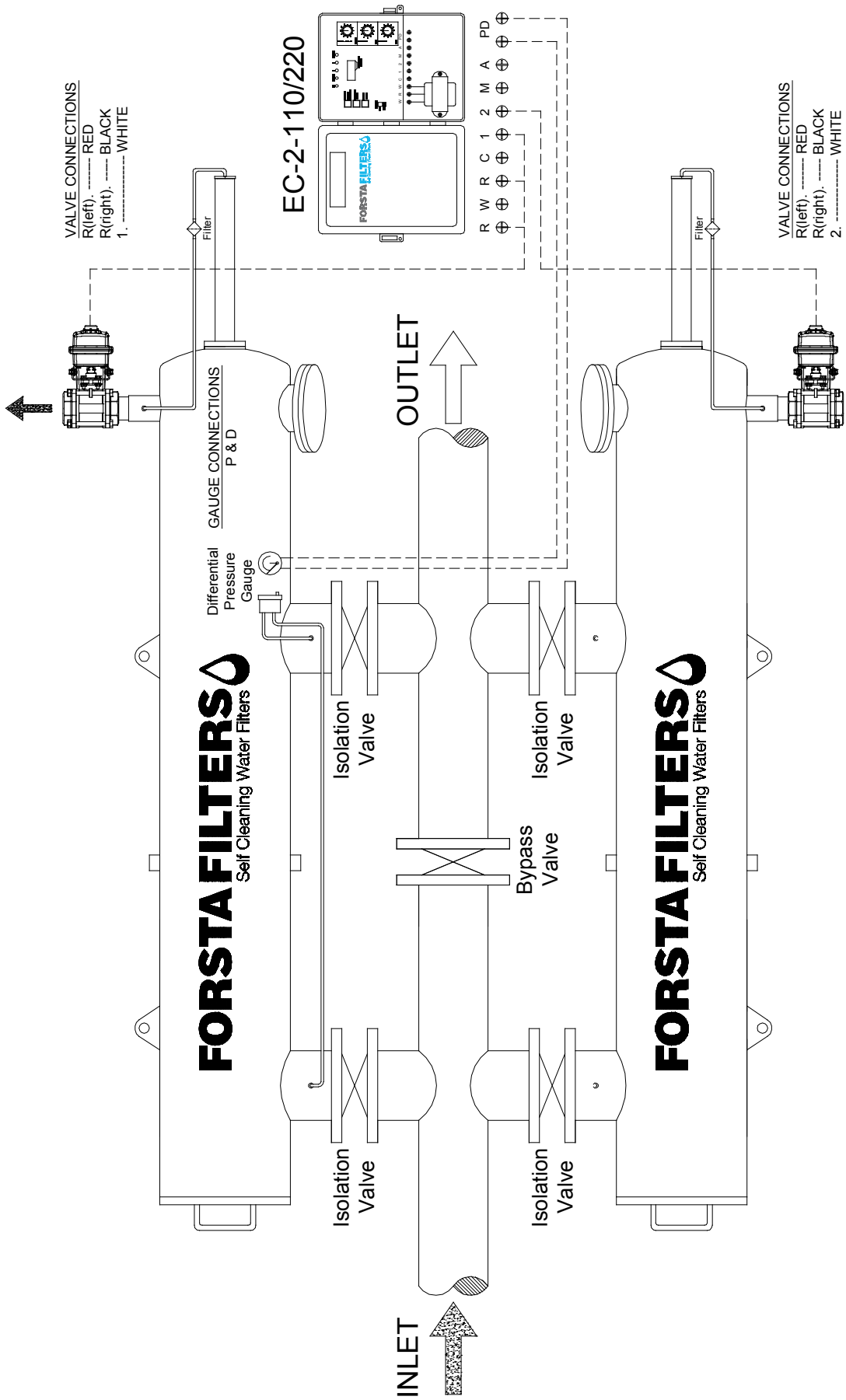

## Warranty

Forsta Filters guarantees all self cleaning water filters, components, and accessories free of defects for one year from the date of installation, or 18 months from the date of original shipment. Forsta will replace any part found defective during the warranty period, provided the equipment in question was handled, installed, and operated in accordance with the operation and maintenance manual and sound engineering practices. Forsta Filters assumes no liability for incidental or consequential damage resulting from the use of its products, services, or data. Liability is limited to replacement or repair of products provide by Forsta Filters, and no agent or sales representative has authority to extend the warranty period without the express written consent of Forsta Filters, Inc. Shipping charges for returned equipment will be at the expense of the purchaser, and all returned equipment must be sent to Forsta Filters.